

Exceptional print quality, flexibility and enhanced sheet handling

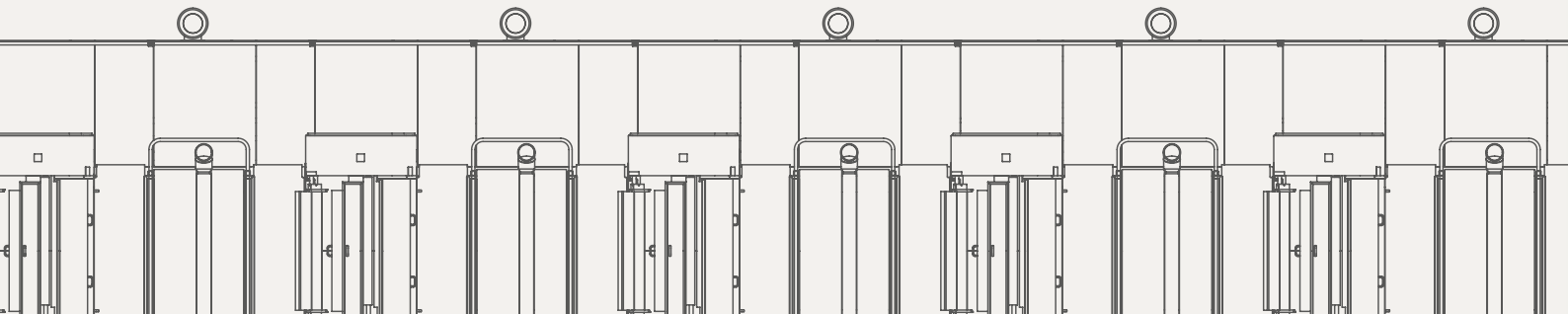

Heritage

Crabtree has been manufacturing high quality metal decorating presses and coating lines for almost 60 years. Our latest machine, the Fastready Pro, builds on decades of development and recent innovations.

EST 1965



Contents

Fastready Pro overview	4
Sheet handling improvements	6
Improved print quality	8
Operator console.....	10
Technical specification	11
Universal sheet feeder	12
Extensive coater portfolio	13
Sheet management system options.....	14
Upgrades, optimisation and service.....	15





Key points

Flexibility

- Compatible with UV, LED UV and conventional inks
- Defect detection camera optional
- Many Inline sheet management station options
- Flat sheet travel throughout

Fast changeovers

- Fully automated CNC infeed and feeder
- Save and load recipes for every setting saved on the HMI
- Semi automatic plate change

Reliable

- Fast, reliable production
- Direct servo drive technology
- Ease of maintenance
- Remote service

Improved print quality

- Specialist PCU cylinder bearings
- Refined printing cylinders
- Latest ink feed technology with enhanced control

Ergonomic

- Fully CE Guarded
- Operator Catwalk
- Localised HMI's on every unit
- Touch screen operator console



Sheet handling improvements

- Precise registration accuracy utilizing direct servo driven sidelays
- Programmable electronic cams for a wide range of substrates
- Full CNC operation with no manual interaction required
- Flat sheet travel throughout
- Various infeed configurations available to suit any type of material



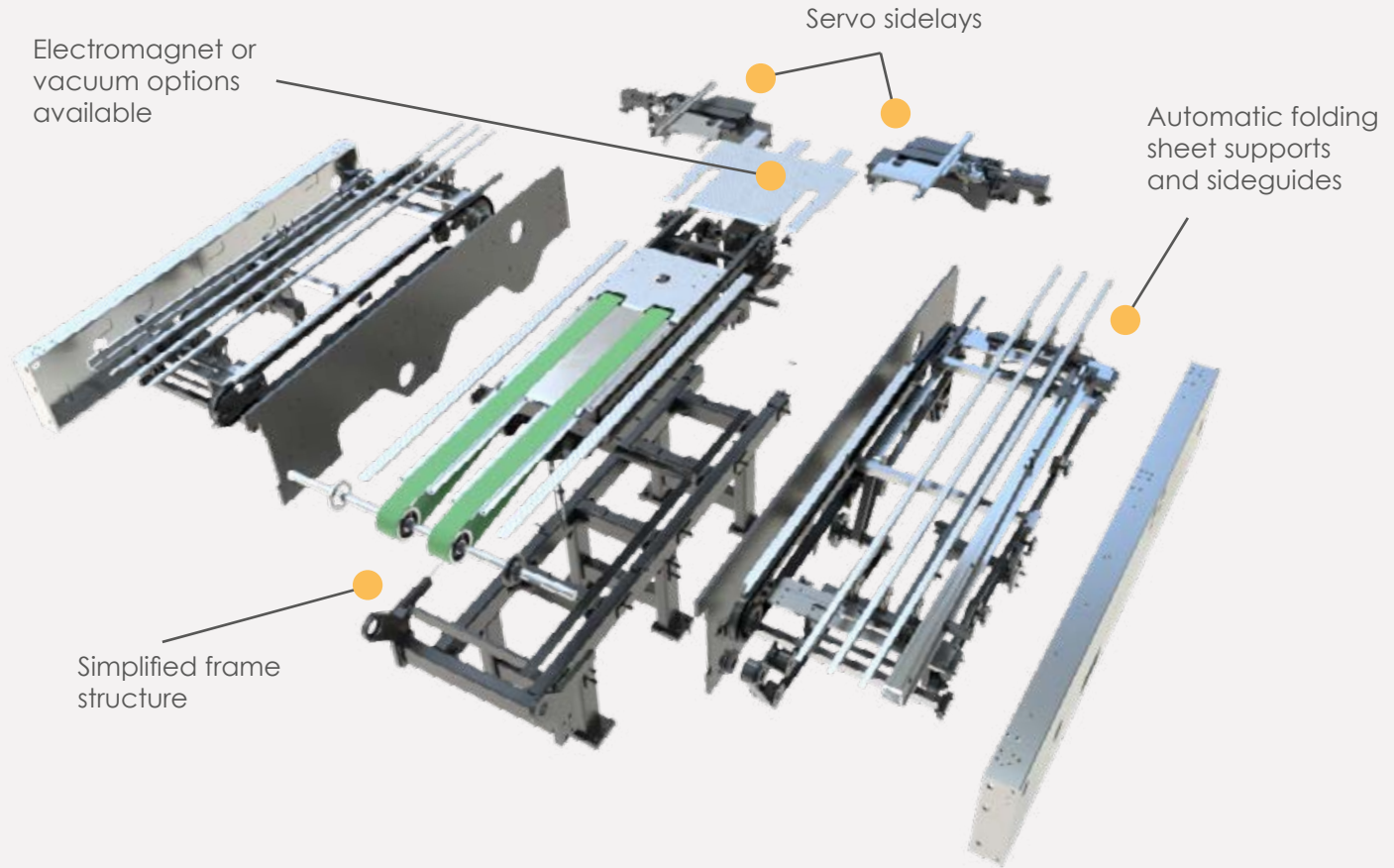

Folding sheet supports and sideguides

Folding sheet supports and sideguides

Full CNC sheet adjustment from 1200mm wide to 710mm without the need to remove any sheet supports

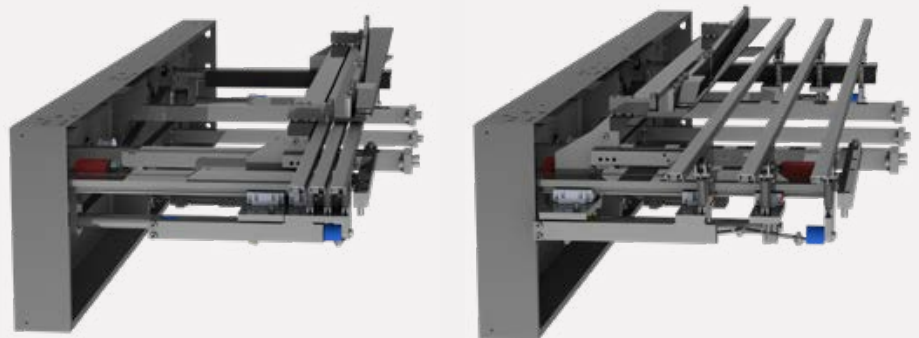

Improved print quality

- Bespoke PCU cylinder bearings for maximum stability, greatly improving colour variation
- Precision high quality printing cylinders

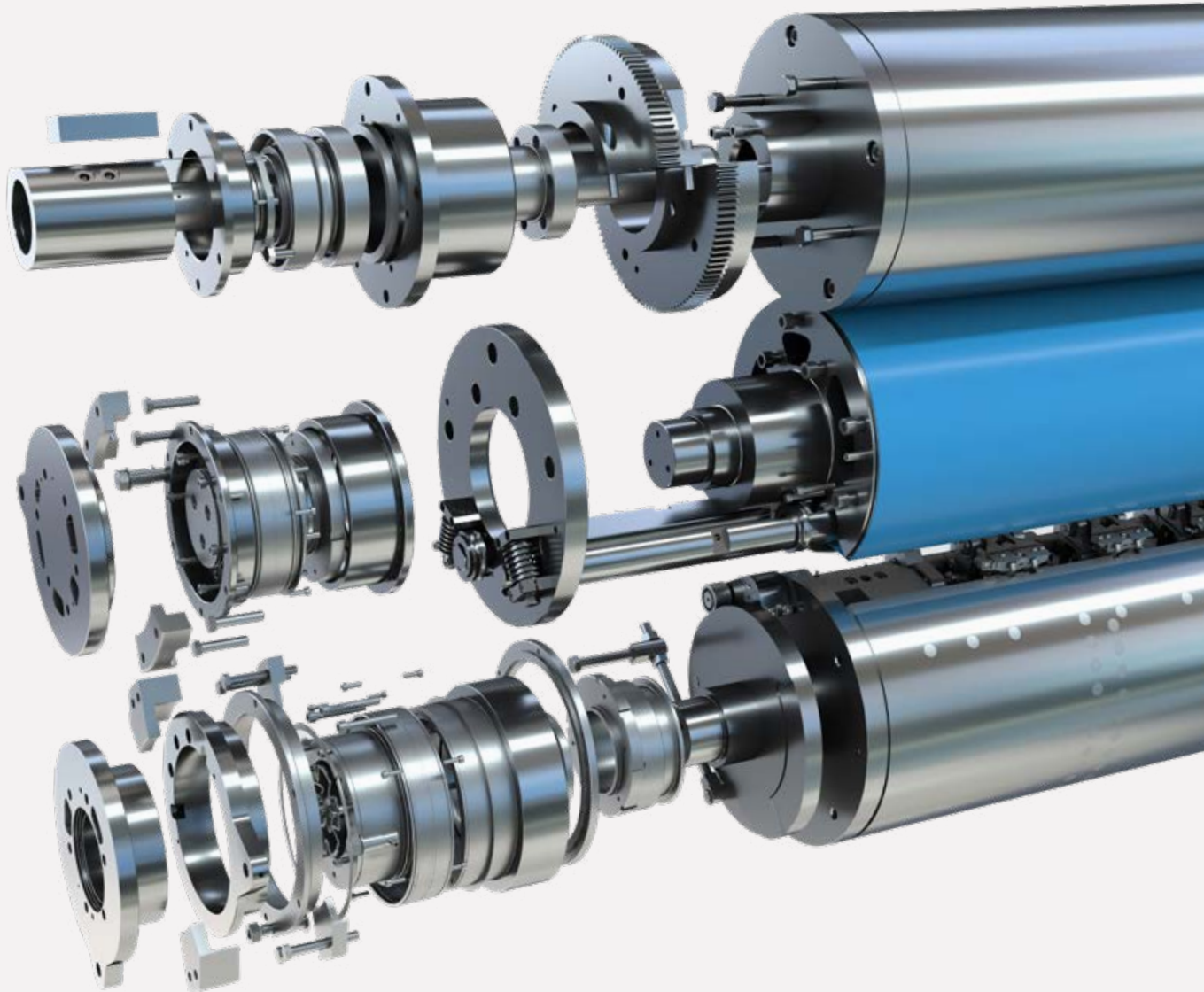

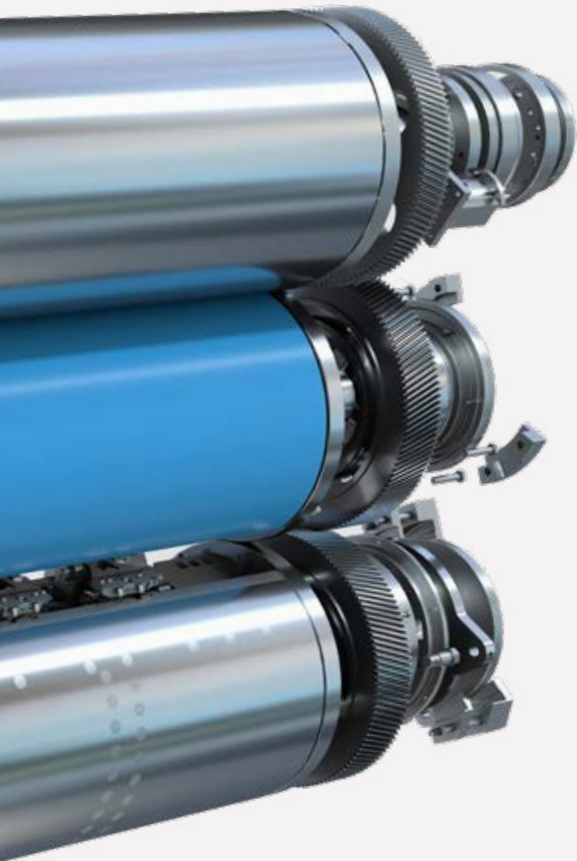

Enhanced ink feed control

- Individually controlled ink zones over the length of the roller, programmable for each job
- Ergonomic and easy to clean duct stay arrangement
- Ceramic coated ink duct roller with independent servo driven roller



Delta dampening system

- Oscillating anti ghosting bridging roller
- Delta roller function for plate cylinder hickey prevention



Operator console

- 24" mainline operator console
- Appealing and elegant design with maximum functionality and intuitive operation
- Localized HMI's on every unit and feeder
- Line operation setup and detailed diagnostic capability
- Save and load recipes for every job
- Remote modem support



Technical specification

Production speed	Maximum (dependent on print shop conditions and ingoing material quality)	7200 sheets/hour
Sheet size	Maximum	1200 x 1000 mm
	Minimum	710 x 510 mm
	Thickness	0.13 to 0.4 mm
Printing area	Maximum	1200 x 995 mm
Printing plate	Width x length	1200 x 1130 mm
	Thickness	0.30 or 0.40 mm
Start of print	From edge of sheet	5 mm
Weight of feeder pile	Maximum	5000 kg
Standard electric power		supply 400 V / 50 Hz, 3 phase
Production speed	Maximum (dependent on print shop conditions and ingoing material quality)	7200 sheets/hour

Crabtree are dedicated to continuous improvement and therefore reserve the right to modify design features and technical specification without notice

Lightweight aluminium
extrusion reject tray

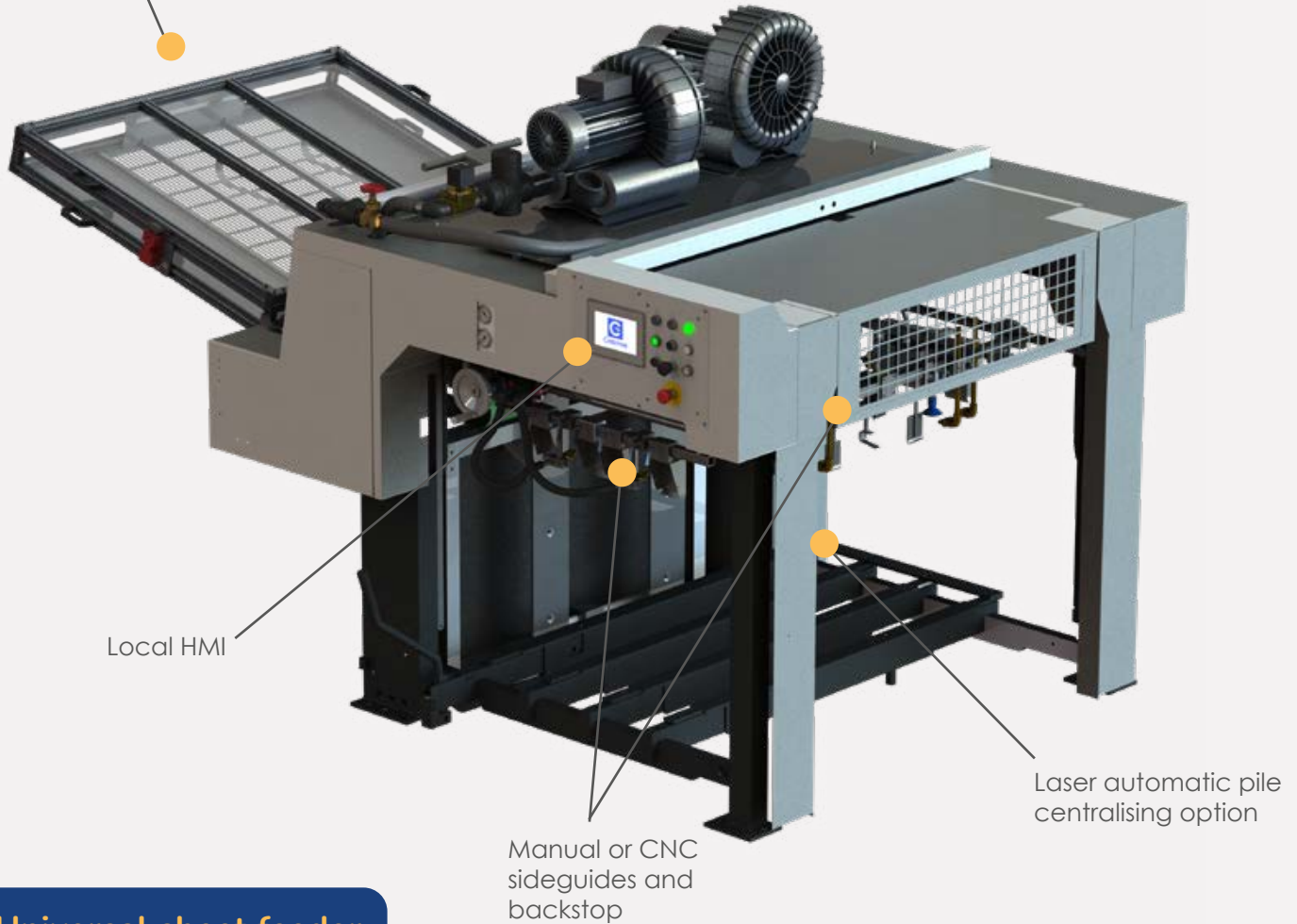

Local HMI

Manual or CNC
sideguides and
backstop

Laser automatic pile
centralising option

Universal sheet feeder

- For press lines, coating lines and any other sheet feed application
- Easy and intuitive operation with a localized HMI
- Reliable and robust
- Optional full CNC with laser automatic pile centralizing, minimizing any manual interaction and guarantee centralised sheet feed
- Lightweight design aluminium extrusion reject tray
- Independently driven camshaft

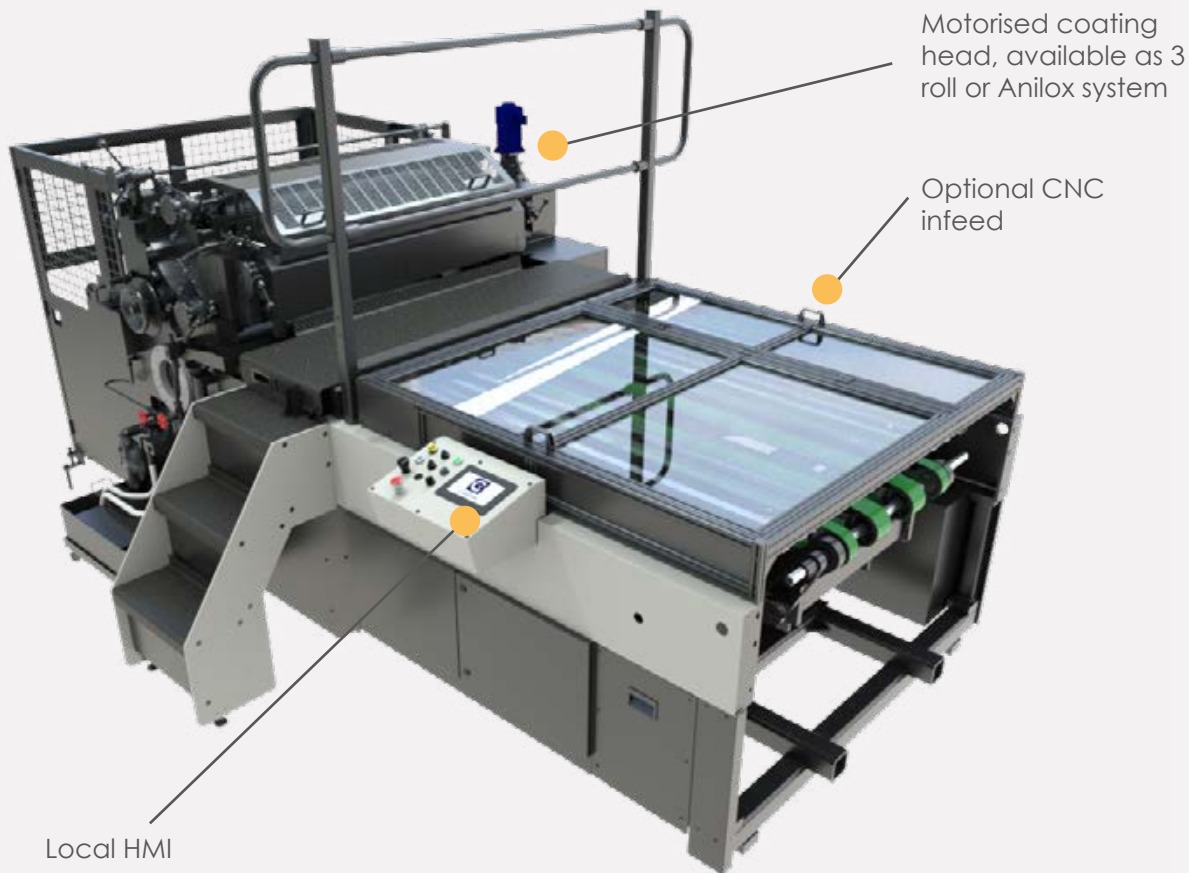

Motorised coating head, available as 3 roll or Anilox system

Optional CNC infeed

Local HMI

Extensive coater portfolio

- Inline or standalone
- Motorised coating head, available as 3 roll or Anilox
- Available as full spot (register) coating, or plain coating option
- Easy operation with Local HMI
- Optional Full CNC infeed
- Secondary scraper option for tough coatings
- Application roller $\varnothing 319$ - $\varnothing 339$ mm ($\varnothing 329$ mm for spot coating)



Sheet management system options

Modular system with 3 options available:

- 1 Overhead eject tray – ideal for sheet quality inspection and small batch eject of up to 20 sheets.
- 2 Single sheet reinsertion – safely reinsert sheets back into the print line with minimal manual interaction

- 3 Inline sheet stacker – up to 200 stacked sheets possible, safely removed with an extractable dolly system. Sheets are precisely stacked using a dynamic braking system and CNC sideguides, meaning sheet are undamaged and fully reusable – ideal for start of line wasters.

- Each option available independently or all together
- Retrofittable with a standalone electrical system

Upgrades, optimisation and service

Existing Crabtree equipment can be upgraded with many of the Fastready Pro features to optimise productivity and print quality.

After an initial survey is carried out, an optimisation path is agreed, replacing outdated components and mitigating electrical obsolescence.

Using only OEM parts and our highly knowledgeable and experienced engineers.

Crabtree’s service engineers can also provide the following benefits:

- Installation of all new Crabtree equipment
- Full mechanical and electrical surveys
- Upgrades and refurbishment for print optimisation
- Targeted training for operators and maintenance personnel
- Technical and service support team, including remote diagnostics

Service maintenance contract

Contract type

Level 1 Contract
Online Support

Level 2 Contract
1 visits per year

Level 3 Contract
2 visits per year

Included

- Free online support for the duration of the contract. Including online fault finding via modem where applicable.
- Training for operators and maintenance personnel.
- Audit of Crabtree equipment to highlight essential areas of concern.
- Set Machine back to factory settings.
- Planned preventive maintenance.
- Advice on printing procedures.



Tel: +44 (0)191 487 5071
Fax: +44 (0)191 487 3997

www.crabpress.co.uk
Kingsway, Team Valley
Trading Estate, Gateshead
Tyne & Wear
NE11 0SU
United Kingdom

