

# PLASMA TREATMENT

ENGINEERED PRODUCT SOLUTIONS

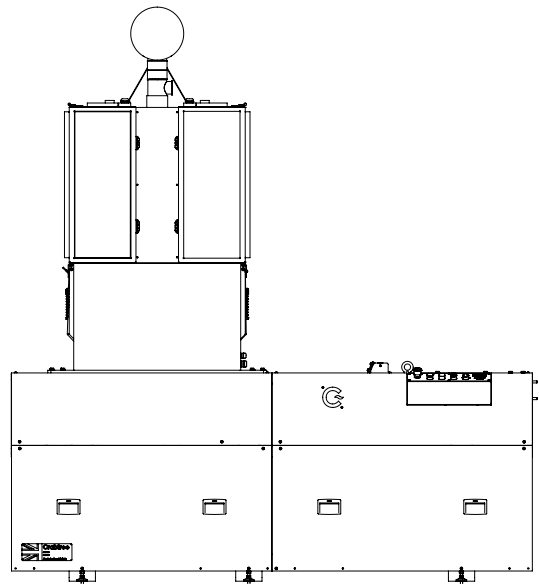
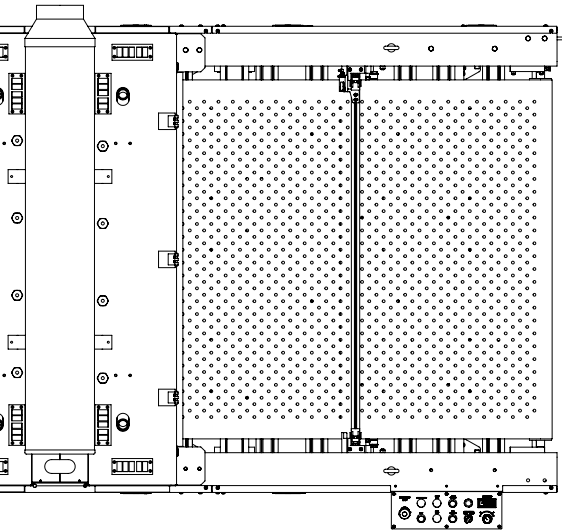

## System Overview

Designed to seamlessly integrate to a coating line, the plasma system enhances the surface energy of virgin metal sheets, improving the adhesion of UV coatings eliminating the need for energy-intensive thermal ovens.



## Plasma

As metal is non-porous, achieving strong adhesion with conventional coatings can be challenging, particularly with solvent-based systems that rely on good surface wetting and often require energy-intensive thermal ovens for curing.

Plasma treatment overcomes this by cleaning and activating the metal surface at a molecular level, increasing the surface energy, and creating reactive sites that improve wettability and promote strong chemical bonding between the substrate and the coating. This results in more uniform coating coverage, improved adhesion, and enhanced durability. Plasma treatment is also an enabling technology for UV-curable coatings, allowing these low-VOC, energy-efficient systems to achieve strong adhesion on metal surfaces without the need for aggressive chemical pretreatments.



Normal UV Coating on an untreated surface



New UV Coating after plasma treatment

## Onsite Testing

Working in a cross-partnership collaboration with Brasilata Labs, Plasmatrete and Actega, the plasma treatment system has been rigorously tested over a 4 year period in a full production environment, yielding very positive results.

Crabtree, as well as supplying the inline coater and feeder, engineered the sheet handling system to perfectly suit the plasma head, providing optimum sheet transfer and stability.



## Unit Description

To be placed between the coating unit and feeder, the Plasma Unit is offered as a retrofit package to an existing setup, or integrated as part of a brand new coating line.

### Plasma Head

With 16 plasma jets providing full sheet coverage

### Vacuum Conveyor

Precise sheet vacuum control keeping the sheet within +/-0.5mm flatness. Magnet section in the plasma jet area for added sensitivity

### System Control

Simple independent control system with settable control speeds

### Unit Size

2500mm long x 1700mm wide  
975mm sheet height (adjusted to suit customer requirements)

### Crash Bar

Crash bar stops the conveyor to protect the Plasma jets from damaged sheets

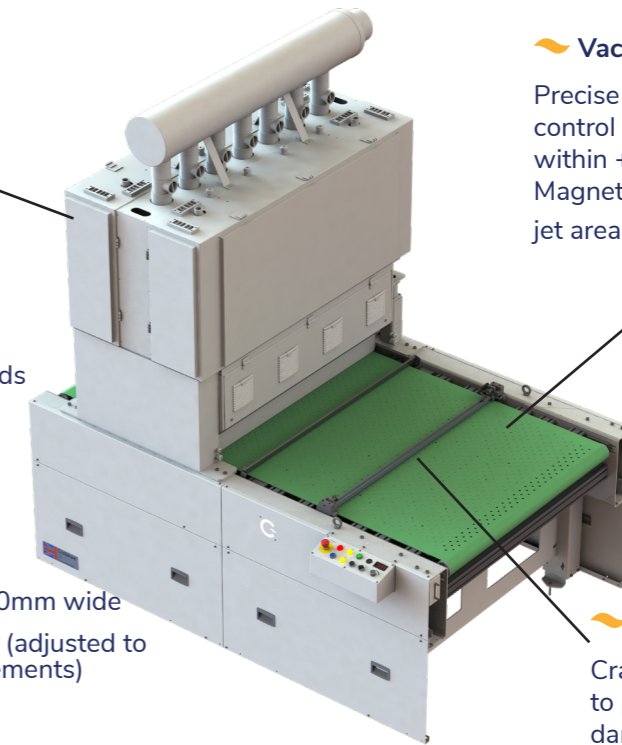

## Benefits

### Full UV Coating

Delivers full UV coating for virgin metal sheets without the need for energy-consuming oven curing.

### Environmental Benefits

Potentially lowers VOC emissions by up to 95%, promoting a cleaner production process. Reduction in carbon emissions by up to 40%.

### Precision Sheet Handling

Fully belted vacuum conveyor system ensures even plasma coating. Sensitive crash bar stops the conveyor to prevent damage to the plasma jets.

### Flexible Integration

This system can operate as a standalone unit or can be easily integrated into an existing production line. Compared to traditional oven curing it provides significant factory space saving benefits.

## Full End-to-End Solution

As an OEM with over 60 years of developing and manufacturing metal-decorating and coating machines, Crabtree can supply a plasma system as part of a fully integrated UV freestanding Coating line, from feeding to stacking.

The system would be complimented with our new FastreadyPro coater, which features all of our latest automation features.

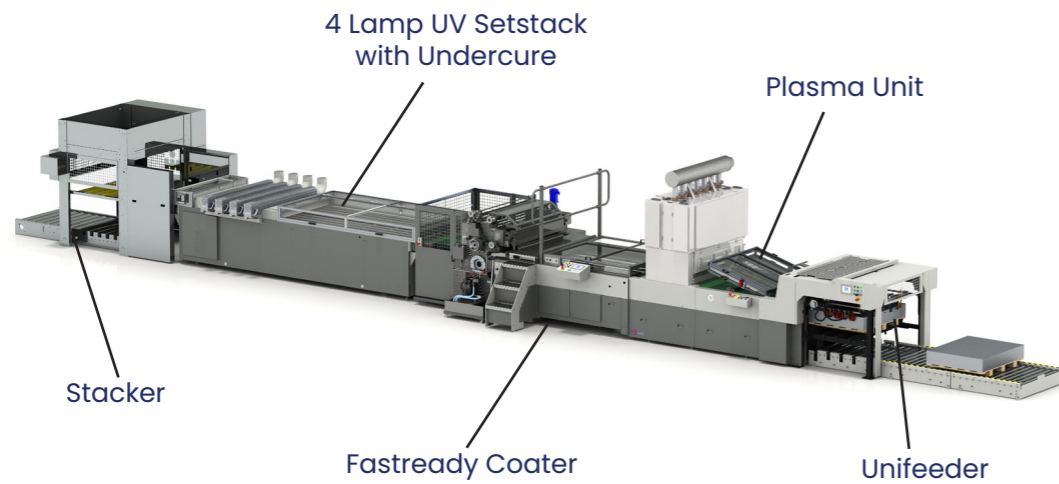

## Latest Fastready Pro Features

Crabtree are committed to continual product development, our latest Fastready Pro coater features high levels of automation to streamline your production processes.



### ~ New Operator Control

The machine control is via the mainline console on the side of the coater, all sheet control settings can be saved and loaded as recipes without any manual input, providing significant setup time savings.

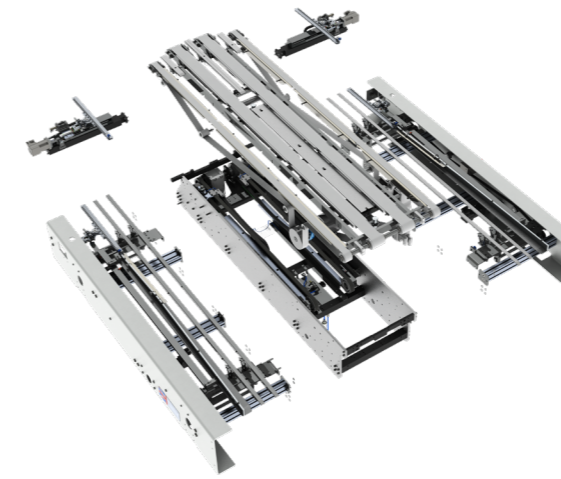

### ~ Servo Infeed

The infeed features fully independent CNC servo axis on each element, as well as a fully belted sheet transfer surface to ensure no sheet scratching on softer materials (such as Aluminium and TFS). With proven high speed register accuracy and reliability, the mechanical simplicity of the system also ensures very low maintenance.

### ~ Motorised Coating Head

Our ergonomic coating head is available as precision 3-roll and Anilox, both options are fully motorised for full control.

A precise coating film weight measurement system is available on request.

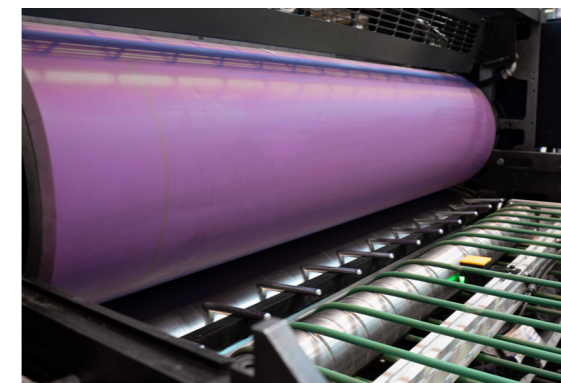
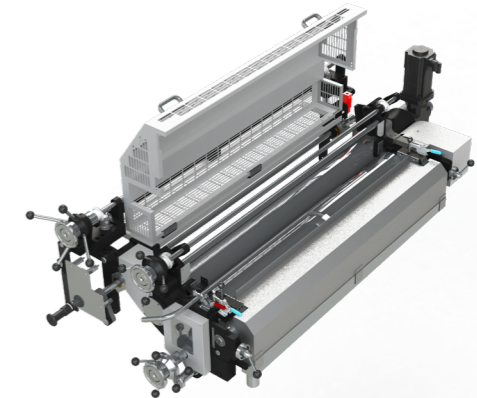

### ~ Optimised Coating Unit

In addition to our proven primary scraper system, for tough coatings (with high solid content) we offer an effective secondary solvent scraper.

The independently motorised delivery unit has been optimised for quick changeovers and operator friendliness.

### ~ Full CNC Feeder

The new independent CNC feeder is equipped with laser Automatic Pile Centralising, ensuring quick changeovers and guaranteed centralised sheet feeding.

We also offer these features on our Double Box Feeder.

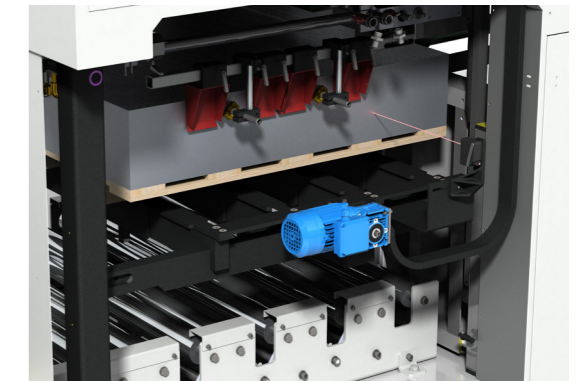

## Fastready Pro Coating Line: Technical Data

Sheet size	Maximum	1200 x 1000mm
	Minimum	710 x 510mm
	Thickness	0.13 - 0.5mm
Application roller $\varnothing$	Spot coating	329mm
	Plain coating (Max)	339mm
	Plain coating (Min)	319mm
Application roller length		1225mm
Compression roller length		1225mm
Varnish tank capacity		80ltrs
Weight of feeder pile (max)		5000Kg
Standard electric supply		400V/ 3 Phase/ 50Hz
Compressed air		6bar/80psi
Mechanical speed (max)		7200SPH*

\*Dependent on factory conditions and ingoing material quality



Crabtree are dedicated to continuous improvement and therefore reserve the right to modify design features and technical specifications without notice

[sales@crabpress.co.uk](mailto:sales@crabpress.co.uk)

+44 (0)191 487 5071